



VENDAS DE RÉGUAS ÓPTICAS DE VARIADOS TAMANHOS, ASSISTÊNCIA TÉCNICA E INSTALAÇÃO EM TODAS AS MARCAS (FOIC, SINO, DIADUR/HEIDENHAIN, FAGOR, MITUTOYO, VEKER, CLEVER, SUPRA SONIC).

FONE: (019) 2117-7438

Site: www.digitechautomacao.com.br

E-mail: digitechautomacao@terra.com.br

MANUAL DE OPERAÇÃO DAS RÉGUAS LINEARES FOIC JCXE / JCXF / JCXG

1. Description

The rolling grating linear displacement transducer has three types, which is small type (for model JCXF), common type (for model JCXE) and large type (for model JCXG). Each type can adopt grating with 50 lines as measuring datum. With the help of digital display device, it can meet the linear displacement digital display of all kinds of medium and small machine tools and other precision measurement.

The reading head of the transducer adopts ball bearing to position and guide, so it has small frictions, high sensitivity and long life.

The transducer adopts precise metrology grating as its measuring datum, so it has high accuracy. To rebuild the imprecise machine tool, it has reality significances. It can greatly improve the machining accuracy and producing efficiency.

The transducer adopts sealed structure, which has reliable performance and is convenient for installation. It has optimum performance than any other digital display systems.

The technical performance refers to the standard 《JB/T 10080.2-2000》 .

2. Technical specifications of JCX grating transducers

| Model | JCXF1 | JCXF5 | JCXE1 | JCXE5 | JCXG1 | JCXG5 |
|-----------------------------|---|-------|-------|----------------------------------|-------------|-------|
| Grating space | 20um(0.020mm), 10um(0.010mm) | | | | | |
| Grating system | Transmission infrared optical measuring system, the infrared wavelength is 880nm. | | | | | |
| Rolling system of read head | Vertical five bearings rolling system | | | 45° five bearings rolling system | | |
| Resolution | 1um | 5um | 1um | 5um | 1um | 5um |
| Effective travel | 50-1000mm | | | | 1100-3000mm | |
| Precision (um) | | | | | | |
| | 50-500 | ±3um | ±6um | ±3um | ±6um | ±3um |
| 550-1000 | ±6um | ±10um | ±6um | ±10um | ±6um | ±10um |
| 1100-1500 | | | | | ±30um | |
| 1600-2000 | | | | | ±50um | |

| | | | | | | |
|------------------------|-----------------------|------|------|----------------------------------|-------|------|
| 2100-3000 | | | | | ±80um | |
| Repeatability accuracy | ±1um | ±5um | ±1um | ±5um | ±1um | ±5um |
| Working speed | >20m/min(1um) | | | >60m/min(5um) | | |
| Environment | Temperature 0-50°C | | | Humidity ≤90(20±5 ⁰) | | |
| Voltage | 5V±5%DC | | | 12V±5%DC | | |
| Output signal | TTL ELA-422-A(RS-422) | | | | ~1VPP | |

3. Working principles

3.1 Grating measurement

The rolling grating linear displacement transducer is composed of the aluminum shaped material, grating scale, mounting end cover, reading head and signal cable (with plug). The grating scale (ruler) is fixed by the aluminum shaped material and the mounting cover fixes the two ends of the shell respectively, thus forms the measuring unit that the grating takes as its datum. The reading head is composed of the four quadrants indicating grating, light source board, receiving board, matching board and cables. There are three ball bearings on the side of the indicating grating and the space between the indicating grating and grating is determined by its position. There are two ball bearings on the top of the indicating grating holder. When the reading head and the grating do the relative movements, the indicating grating adhibits the score surface and the top of the grating all the time. The light source and receiving boards on the two sides of the indicating grating receive the light source and grating Moire fringe respectively. The optoelectricity signal becomes the displacement number after processed by the digital display device, thus complete the measurements of grating to linear displacement. For convenience processing for the digital display device, in the transducer, the optoelectricity signal of Moire fringe is inputted the signal cable after processing.

In short, the rolling grating linear displacement transducer is consisted of the two parts of shell with grating scale and reading head with signal cable.

3.2 Optoelectricity conversion

The rolling grating linear displacement transducer adopts four quadrants indicating grating, so it has four group lights, receiving system, zero windows with independent light and receiving system, which adopts infrared diodes and optoelectricity dynatrons as light and receiving parts.

The light source passing through the 5VDC limits the current and then supplies the light emitting diode. The working current is constant to ensure the stability of the receiving signal.

3.3 Zero window signals

The rolling grating linear displacement transducer has a zero (reference) window. When the reading head passes through the marks of the scale, the reading head outputs a positive pulse. The pulse signal inputs the digital display device. Then the device processes it to obtain the position of the grating measurement. The digital device decides the content function.

4. Completing set for the order

4.1 For JCXF model

- JCXF transducer 1 piece
- Mounting screws 1 set
- Certificate (Quality guarantee) 1 copy
- Operation manual for products 1 copy

4.2 For JCXE model

- JCXE transducer 1 piece
- Mounting screws 1 set
- Certificate (Quality guarantee) 1 copy
- Operation manual for products 1 copy

4.3 For JCXG model

- JCXG transducer 1 piece
- Mounting screws 1 set
- Certificate (Quality guarantee) 1 copy
- Operation manual for products 1 copy

5. Install and inspect

5.1 Installing position

- The working length of the transducer is more than the maximum travel of machine tool to avoid destroy the optical ruler.
- For the mounting surface of the transducer, only it is the non-mechanical machining face, some washers or pads must be used to the transducer to ensure the reliability of the connection between the transducer and the mounting surface.
- When mounting the transducer, the parallelism between the transducer ruler surface and the guide rails of the machine tool is smaller than 0.1mm, and the maximum value doesn't exceed 0.15mm. When the length of the transducer ruler surface is more than 1000mm, mounting pads should be installed to ensure the parallelism.
- The two sides of the reading head and transducer ruler surface is parallel and symmetric. The span between the reading head and high and low directions of the transducer ruler surface is the range of 0.8mm to 1mm. Adjust the span with washers. Remove the washer after installing.
- Fixing the signal wire should be considered the all relative moving distance. The fixing position should try to be in the middle of the travel and fixes the other wires.

□ The ground wire should be towards right side and the ground resistance measured by multimeter must be smaller than 10Ω .

Try to accord with the Abbe principle and ensure the good relative movements between the reading head and the shell. And avoid directly pollution and disturb the operation.

5.3 Attentions for mounting

1. The opening direction of the transducer should avoid the pollution of scrap iron, oil, water and dirt.
2. A space of 0.5mm between the dustproof cover and the ruler must be existed after installing the transducer. When moving the reading head, try to avoid the dustproof cover contacting with the ruler.

5.4 Inspecting method

Firstly inspect the parallelism between the transducer and the guide rails and make it in the range of 0.10mm. Secondly, open the digital display device and run the machine tool to observe whether the count is normal. If it doesn't count, should carefully check the connection between the digital device and the transducer. If counts, move the reading head onto one side of the shell and zero the digital display device. Moving the reading head, the difference between the display value of the digital

device and the standard value should be in the range of error. If it exceeds the error, then carefully check the mounting size and the mounting position whether accord with requirements.

6. Maintenance

6.1 The transducer and digital display device should be placed in the position of machine tool, which is dry and moderate temperature.

6.2 The derivative cables should be fixed onto the machine tool.

6.3 The transducer should not be taken down at random in the course of operation.

6.4 The connecting screws should be locked and not be loosened to ensure the accuracy.

6.5 The instrument should be kept clean. The dustproof rubber, if has dust, it should be wiped off with soft paper. After using for one year, the shell surface should be cleaned with dry clean emery cloth or cotton dipped with the mixer of alcohol and ether. Don't wipe off with strong force to avoid destroy the surface.

**Mounting sizes:
For JCXE1 and JCXE5**

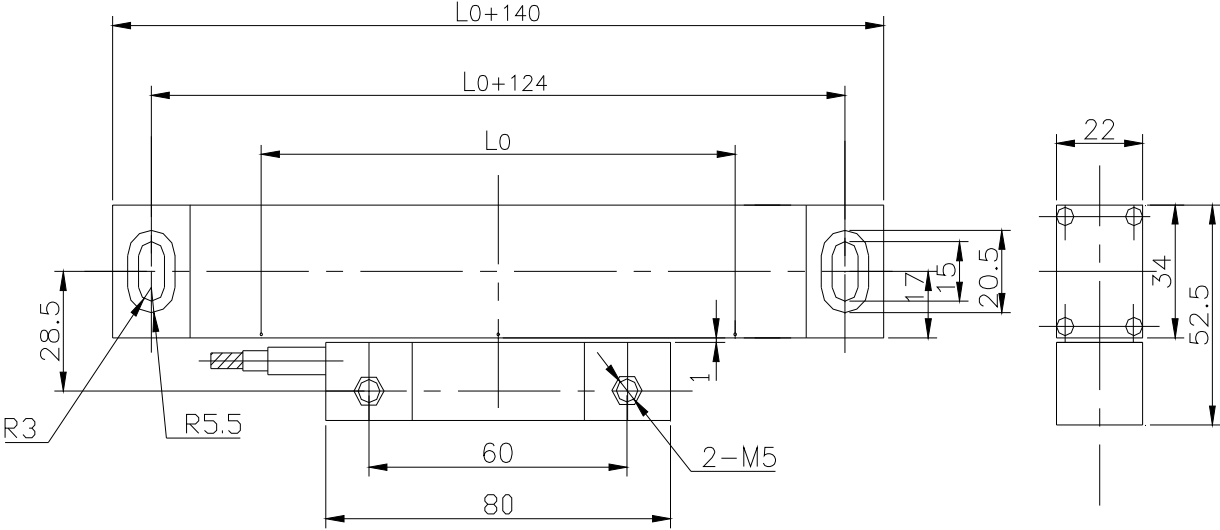

L_0 : Effective working length ≤ 1000 mm

**Mounting sizes:
JCXG1 and JCXG5**

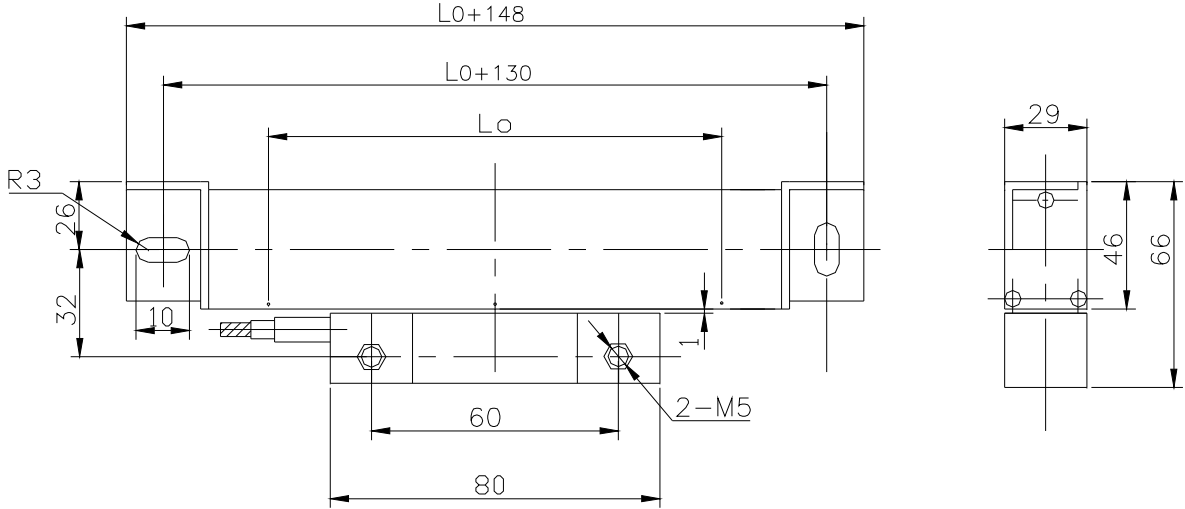

L0: Effective working length ≤6000mm