

MOTOR DE PASSO KTC-HT23 / NEMA 23

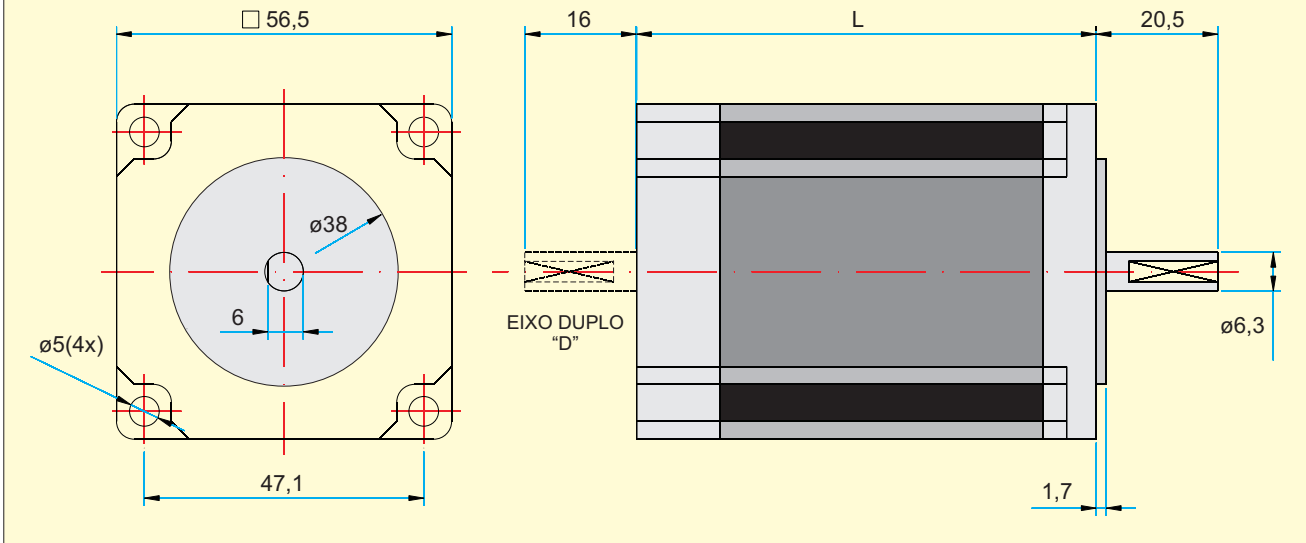

MODELO	LIGAÇÃO DO MOTOR 1=SÉRIE 2=PARALELO 3=UNIPOLAR	COMPRIMENTO "L" (mm)	MINÍMO TORQUE ESTÁTICO (N.m)	FIOS	STEP (ÂNGULO)	VOLTS	AMPS	OHMS	mH	ROTOR INÉRCIA (g.cm ²)	MOTOR PESO (Kg)
KTC-HT23-394	1	40,6	0,54	8	1,8	4,0	1,41	2,8	5,6	120	0,45
	2					2,0	2,38	0,7	1,4		
	3		2,8			2,00	1,4	1,4			
KTC-HT23-397	1	59	1,25	8	1,8	5,1	1,41	3,6	10,0	300	0,69
	2		2,5			2,38	0,9	2,5			
	3		3,6			2,00	1,8	2,5			
KTC-HT23-400	1	76	1,86	8	1,8	6,4	1,41	4,5	14,4	480	1,00
	2		3,2			2,38	1,1	3,6			
	3		4,5			2,00	2,3	3,6			
KTC-HT23-401	1	76	1,86	8	1,8	4,2	2,12	2,0	6,4	480	1,00
	2		2,1			4,24	0,5	1,6			
	3		3,0			3,00	1,0	1,6			

